

**TELEWELD**  
INC.

***THE  
TELEBRINELLER  
SYSTEM***



**Product Information**

**Now You Can Measure Brinell  
Hardness Anywhere  
In the Field • In the Plant •  
In the Lab**

## ***THE TELEBRINELLER SYSTEM***

The Telebrineller system is a major achievement in quality assurance. Developed for use by its own welding crews in the field, Teleweld, Inc. has based this system on proven metallurgical knowledge supported by more than fifty years of field experience.

**LIGHTWEIGHT:** The complete Telebrineller system, in its case, weighs less than ten pounds. Easily transported to any location, it is highly practical for all Brinell hardness testing needs.

**SIMPLE OPERATION:** One hammer blow, measurement of the resulting impressions, and the manipulation of a basic equation on the computer provided—that's all. No special training required. In a few minutes, anyone can learn to determine BHN accurately.



### **CERTIFIED ACCURACY:**

The test bars which are the core of this system are calibrated to a uniform hardness of  $\pm 3\%$  of the labeled BHN. Hardness of the bars is measured by equipment whose accuracy is certified traceable to the National Standards Institute. Readings may be made within .05 millimeters.

### **WEATHERPROOF:**

Designed for field use; there are no delicate adjustments or fragile components to be concerned with. All parts are rugged, solid, able to deliver accurate measurements in all weather, under the roughest field conditions.

A test bar of known BHN, approximating the hardness of the specimen to be tested, is selected. Consistent accuracy is maintained when the test bar BHN is within 15% of the specimen BHN and is of the same general material. (Testing non-ferrous materials with carbon steel bars causes impact errors that must be compensated for by applying correction factors to the test results.) The test bar is inserted into the Telebrineller instrument and the instrument placed upon the specimen.

When the Telebrineller instrument is complete with test bar (1), the anvil (2), encased in a soft molded rubber head (3), rests on the test bar. The rubber head and a similar resting block (4), provide non-skid footing. Below the test bar, a steel impression ball (5), secured in the base of the head, is in contact with both the test bar and the specimen. The anvil is struck sharply with a three to five pound hammer. The impact, regardless of force, is transmitted equally to the test bar and, through the impression ball to the specimen metal (6), making impressions in both. The diameters of the resulting impressions are directly related to the respective hardnesses of the test bar and the specimen.

A spacing bar (7), operated by a spring catch and button, adjusts the test bar to a clear area for each test. By turning the bar to utilize the full length of all four faces, a total of 80 tests can be made with one bar.

## **MEASURING DIAMETERS**

The bar is removed from the instrument and the Telebrineller Microscope positioned over the appropriate impression. The microscope provides a scale of 1/10 millimeter divisions and is designed so that the image and scale are bright and clear to the observer.

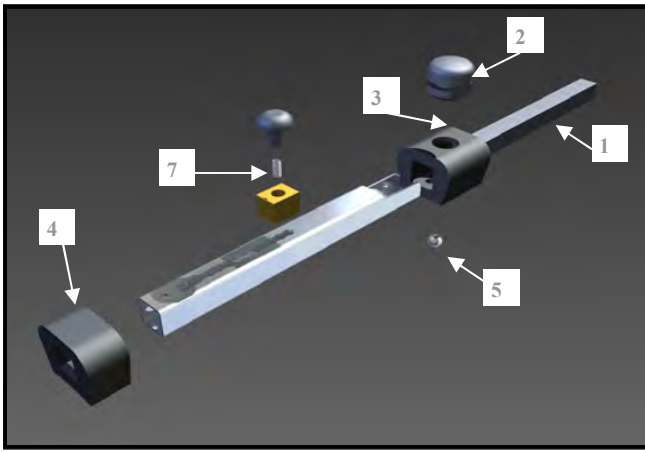

A numbered division is aligned tangent to the impression and the diameter measured by the division that falls over the opposite tangent. Readings may be made easily and accurately within .05 millimeters. The impression in the specimen metal is measured in the same manner. Both measurements take just a few moments.

Determining BHN—The Brinnel hardness of the specimen metal is determined quickly with a simply mathematical equation.

$$\left( \frac{\text{Diameter of Impression in Bar}}{\text{Diameter of Impression in Metal}} \right)^2 \times (\text{BHN of Test Bar}) = \text{BHN of specimen metal.}$$

EXAMPLE: Assume the impression diameter of the test bar is measured to be 3.05; the impression diameter of the specimen metal, 3.15; and the labeled BHN of the bar is 352.

$$\left( \frac{3.05}{3.15} \right)^2 \times 352 = .968 \times .968 \times 352 = 330$$

thus the BHN of the specimen metal is 330.

This computation is simplified with the use of the Telebrineller Computer or any pocket calculator. Complete instructions are included on every Telebrineller system. Telebrineller replacement parts and test bars of hardnesses from 100 to 600 BHN are always available. Contact Teleweld for pricing and ordering information.

## TELEWELD, INC.

# MODEL 239-21 BRINELL MICROSCOPE

### QUICK and EASY MEASUREMENTS OF BRINELL IMPRESSIONS

## TELEWELD, INC

Teleweld, Inc. offers a rugged, stable, free-standing portable instrument for reading brinell impression. The high quality optics in the 10x focusable eyepiece and 2x objective provides 20x total magnification.

#### EYEPIECE

10x wide field (22mm F.O.V.), high eye point with foldable rubber eye guard.

#### OBJECTIVE

2x magnification-doublet housed in an aluminum retainer aligned and calibrated.

#### RETICLE

Easy to read glass reticle with 0-5mm linear scale in 0.1mm increments

#### HOUSING

All aluminum lightweight housing cushioned with a shock absorbing textured grip

#### NOSEPIECE

Stainless steel, reversible nosepiece allows the unit to be free-standing or flip and gain access to those hard to reach areas.

#### LIGHTING

The Brinell Microscope may be used under normal room or outdoor lighting conditions. Attached is a battery-powered (2-AA) included, adjustable beam light source. The L.E.D. light source pivots for compact storage.

#### CALIBRATION

Factory calibrated for magnification and focus. To focus to the individual users needs, simply rotate the focusing eye piece. An optional calibration standard is available.

#### ORDERING INFORMATION

##### Catalog Number

239-21

##### Description

20x Brinell Microscope with focusable eye piece, reticle, and illuminator

239-31

Calibration disc.

## MODEL 239-21



# OPERATING INSTRUCTIONS



Remember to Always Wear Eye Protection

- 1 Insert 9/16" square test bar in hardness tester by lifting anvil with bar.
- 2 Place Hardness tester perpendicular to surface to be tested.
- 3 Press down until give is felt in spring loaded anvil. Failure to press down may damage nose cone.
- 4 Strike with 2 to 3 pound hammer.
- 5 Follow instructions for use of Telebrineller to determine hardness of material.
- 6 Move previous impression just past edge of bar holder for next hardness test.
- 7 To replace impression ball, knock out used ball with flat nose punch, drive new ball into place with small hammer.

Nose piece can be inverted to read fillet welds.



## **TESTING NON-STEEL MATERIALS WITH THE TELEBRINELLER**

Standard TELEBRINELLER test bars are made of rolled carbon steel and carbon steel alloys. These bars are most suitable for testing similar materials.

When these standard test bars are used for testing other materials such as cast iron, aluminum, brass, etc., impact errors usually occur. The impact error for a given material is constant and can be determined in the following manner.

Using a sample of the material to be tested, determine its hardness on a standard brinell machine. The load should be such that an impression with a diameter of 2.5 to 4.0 mm. is obtained. On this same material, make a hardness test with the TELEBRINELLER using a standard bar within 20 BHN points of the material being tested.

On low ductile materials, the TELEBRINELLER test will usually show a lower hardness than the standard brinell machine. As an example, on a certain type of aluminum the TELEBRINELLER may show a hardness of 120 BHN while the standard machine will show 132 BHN. Thus there is an impact error of 10% and all readings obtained with the TELEBRINELLER on this material can be multiplied by 1.1 to obtain the actual hardness.

If the TELEBRINELLER user desires the most accurate results on the materials with an impact error, the only solution is to fabricate test bars from the same material that is to be tested. This is costly and time consuming although we do have a limited assortment of aluminum test bars available from stock.

## ***TELEBRINELLER ACCURACY***

Standard Telebrineller Test Bars are guaranteed to have a uniform hardness within plus or minus 3% of the BHN etched on the end of the bar. They are made of various alloys of carbon steel and finish ground to 9/16" square.

To calibrate, three impressions are made on each bar with a Tinius Olsen Air-O-Brinell Tester with accuracy certified traceable to the National Institute of Standards. For bars harder than 207 BHN, a 3000kg load is used while softer bars are impressed at 1500kg. a 10mm diameter Tungsten Carbide ball is used in both cases.

The diameters of the impressions are then measured and converted to Brinell Hardness Numbers using a King-Scan, computerized, calibration system, the accuracy of which is traceable to the National Institute of Standards. The resulting Brinell Hardness Numbers are rounded to the nearest standard BHN occurring at a .05mm interval in Table I of ASTM Standard E10 and this BHN is etched on the end of the bar.

Please note the accuracy of any test made with the Telebrineller is dependent upon the relative hardness of the test bar and the test piece. When the Telebrineller is properly used, accuracy of +/- 5% is consistently attainable, provided that the BHN of the test bar does not differ from the BHN of the test piece by more than 15%.

## **TELEBRINELLER TEST BARS**

Following is the list of Brinell Hardness Numbers (BHN) to which Telebrineller bars are calibrated.

At any given time, our inventory will contain most of the hardness listed. If you are looking for a specific requirement, please contact us concerning availability.

627	352	229	147
578	341	223	142
555	331	217	138
534	321	212	135
514	311	207	131
495	302	200	127
477	293	194	124
461	285	188	121
444	277	182	117
429	269	176	114
415	262	170	111
401	255	165	109
388	248	160	106
375	241	156	
363	235	151	

## **TEST BAR AVAILABILITY**

Sometimes it is impossible for us to supply a customer with bars of a specific Brinell Hardness in a timely manner. We hope that an explanation of the manufacturing process for Telebrineller Bars may help you understand how this problem occurs.

During the course of a year, we process between 15,000 and 20,000 Telebrineller Bars calibrated to 60 different hardness between 106 BHN and 627 BHN. They are fabricated from a wide assortment of carbon steel bar stocks used in the as-rolled condition or subjected to various heat treating procedures. They are typically processed in batches of 100 to 300 pieces and the bars yielded from each batch are carefully documented.

When, as an example, we find ourselves running out of 223 BHN bars, we review our records to determine what materials and processes have yielded 223 BHN in the past. We then begin the process one or several batches of these materials.

It is very important; however, to understand that producing a piece of steel to a specific hardness is not like producing one to a specific size. Sizing can be done with great precision but, because of variations from batch to batch in steel chemistry, mill work hardening, and heat treating results, hardness can only be approximated.

## ***TEST BAR AVAILABILITY (CONT'D)***

A material and process that yielded a good percentage of 223 BHN Bars from a previous run may produce on 229 BHN and 235 BHN the next time. Though we do take samples, during the processing of each batch, to give us an indication of the potential yield, we cannot know the actual results until all the bars in the batch are calibrated. There is, therefore, always a measure of luck involved in acquiring bars of a specific BHN and sometimes, when luck runs against us, it may require several months before we can rebuild that stock.

However, such a shortage in our inventory should not usually be serious problem for our customers. In most cases, when our stock of specific bars depleted, we will be able to supply the next standard BHN above or below it.

A given Telebrineller Bar can be used to test material 15% harder or softer than the bar with no loss of accuracy. Returning to our example, a 223 BHN is therefore, suitable for testing materials between 190 and 256 BHN. If however, 223 BHN bars are not available and we offer 229 BHN instead, the suitable testing range would be from 195vBHN to 263 BHN. Since there is an 84% overlap in the usable range of these two bars, it is apparent that they can usually be interchanged with no inconvenience. The same would hold true for any Bars of sequential BHN throughout the Brinell range.



# HALTEMAN

## FILLETESTER

The Halteman Filletester is designed for the Brinnell Hardness testing of fillet welds and other hard to reach areas.

LOW COST



BRINELL HARDNESS TESTING  
OF FILLET WELD NOW  
MADE POSSIBLE IN  
THE FIELD OR  
PLANT

ACCURATE

### FOUR STEPS TO SIMPLE USE:

1. Insert Bar
2. Press Down
3. Strike with Hammer
4. Read Impressions

It is used in conjunction with the Telebrineller manufactured by Teleweld, Inc. For easier handling, it is recommended that the standard Telebrineller Test Bars be cut in half. Impressions can be measured by using the 5/8" diameter end of the microscope nose piece.

## **TELEBRINELLER MAINTENANCE TIPS**

**1. Repairing the Bar Holder Assembly:** All parts of the Bar Holder are replaceable and available from Teleweld, Inc. (See separate parts price sheet).

Disassembly and reassembly procedures are as follows:

**A) For Front End Parts**

- 1)** Insert a small screw driver between the bottom of the Rubber Front Piece (3) and the Bar Tube (8). Pry the rubber down to clear the retaining pins and pull the rubber assembly from the tube.
- 2)** Push the Impression Ball (5) out of its socket toward the inside of the Rubber Front Piece.
- 3)** Insert a small screw driver under the head of the Anvil (2), work it past the rubber collar and under the base of the Anvil. Pry the Anvil up and out of the Rubber Front Piece.
- 4)** Replace the Anvil by inserting one end of its base into the Rubber Front Piece. Insert a small screwdriver up through the hole in the Rubber Piece at the opposite end of the Anvil so that the Anvil can be pried down into position.
- 5)** Replace the Impression Ball by pushing it on the end of the Bar Tube until the retaining pins seat in their sockets in the rubber Front Piece.
- 6)** Reinstall the entire assembly by pushing it on the end of the Bar Tube until the retaining pins seat in their sockets in the Rubber Front Piece.

**B) For Back End Parts:**

- 1)** Grasp the top of the Rubber Rear Piece (4) and pull it off the Bar Tube (8).
- 2)** Slide the Space Block Assembly (7) all the way to the back end of the slot in the Bar Tube and pull the Spacer Button out through the hole in the end of the slot.
- 3)** Slide the Space Block and Spring out of the end of the Bar Tube.
- 4)** Reverse the above steps to reassemble the Spacer Block Assembly and Rubber Rear Piece to the Bar Tube.

**2. Maintaining Accuracy:** There are only two elements in the Telebrineller system whose deterioration can cause inaccurate tests.

**A) The Impression Ball:** After many tests the Impression Ball (5) may become deformed and cause out of round impressions. Check the ball by measuring it across multiple axes with a micrometer. If variations of greater than .0005 inches (.01 mm) are detected, replace the ball.

**B) The Microscope:** While very unlikely, the Brinell microscope may be knocked out of calibration. Its accuracy can be checked against a stage micrometer (calibration disc), available from Teleweld, or any flat and accurate millimeter scale. If a scope is out of calibration, or otherwise damaged, it should be returned to Teleweld, Inc.